

saxby  
lighting



**Opal Post**  
**Opal Bollard**

13829

13830

Thank you for purchasing this light fitting.  
Please read the instructions carefully before use to ensure safe and satisfactory operation of this product.  
Please retain these instructions for future reference.

## Warning

### **This is a Class I product and must be earthed.**

Please read these instructions carefully before commencing any work.

This unit must be fitted by a competent and qualified electrician.

Install in accordance with IEE Wiring regulations and current Building Regulations.

To prevent electrocution switch off at mains supply before installing or maintaining this fitting. Ensure other persons cannot restore the electrical supply without your knowledge. If you are in any doubt, please consult a qualified electrician.

This light fitting should be connected to a fused circuit.

If replacing an existing fitting, make a careful note of the connections.

Always use the correct type and wattage bulb. Never exceed the wattage stated.

When changing a bulb, always switch off at the mains and allow the old bulb to cool down before handling.

Dispose of used bulbs carefully and responsibly.

Waste electrical products should not be disposed of with household waste. Please recycle where facilities exist.

Check with your local authority or retailer for recycling advice.

This product is rated at IP44.

This product is not suitable for location in or near a marine environment.

The entire unit gets hot whilst on for a period of time.

## Specification

Voltage:	240V 50Hz a.c.
Lamp:	60W E27 (ES) or 11W E27 (ES) Compact Fluorescent
IP rating:	44

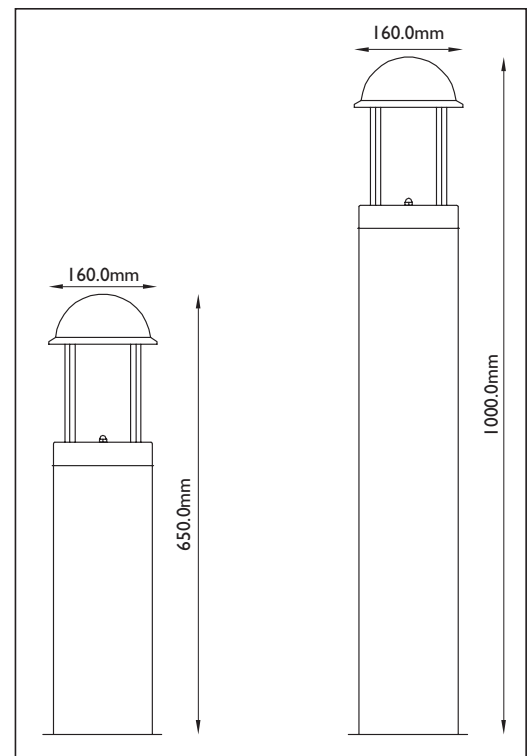

## Layout

- These fitting must be mounted on either a concrete surface or a paving slab that has been concreted in position
- Plan the desired layout of this fitting carefully, ensuring the cables will reach the distance between the junction box and the light fitting.
- Avoid locating any cables in positions that would cause a hazard. Position cables and outdoor rated junction boxes (not supplied) away from areas where they may be at risk from being cut, trapped or damaged.
- We recommend that you use H05RN-F specification cable (not supplied) which is an outdoor grade, rubber sheathed cable. The mains supply cable must have a minimum cross sectional area of 1.0mm<sup>2</sup>
- Cables must be protected using suitable conduit or plastic trunking.

## Installation

Existing fittings must be completely removed before installation of a new product. Before removing the existing fitting, **carefully note the position of each set of wires**.

1. The product must be mounted onto a concrete base. It should not be directly installed in the soil.
2. Undo the two domed nuts under the bottom louvre, lift off the shade and set aside.
3. Undo the three nuts to remove the lampholder assembly. Set aside. Remove the outer cover and fixing kit that is secured internally.
4. This product comes complete with expanding bolt type fixings (C) which are suitable for use on most surfaces, however alternative fixings may be required.
5. Push the fixing bolts into the mounting holes.
6. Position the conduit or plastic trunking so that the cable comes up at the centre point of the bollard. Ensure that the cables do not snag.
7. Fit the product over the fixing bolts, re-fit the plastic washers (B) and then the dome nuts (A). Use a suitable spanner to securely tighten the product onto the mounting surface.

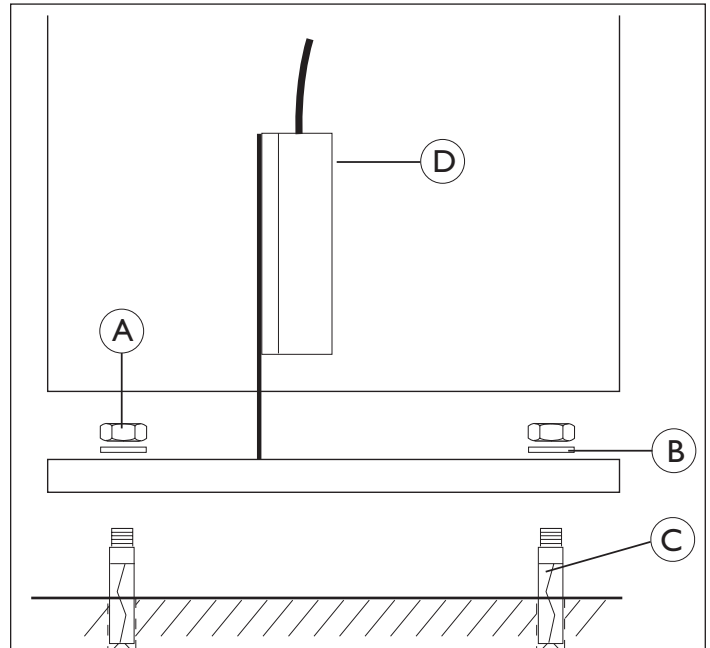

## Wiring

Having correctly identified the wiring from your existing light fitting, pull the wire through the hole and connect to the connection block inside the product in the following way:

5. Pull terminal block (D) from inside of tube.
6. Unscrew the 4 screws which attach the black box to the spacing strip. Open the black box and pull out the terminal block.
7. Connect Live input wire to brown wire on product (or terminal on terminal block marked 'L').
8. Connect Neutral input wire to blue wire on product (or terminal on terminal block marked 'N').
9. Connect Input Earth wire (Green/yellow) to Earth wire on fitting.
10. Check that you have correctly identified the supply wires, the connections are tight and that no loose strands have been left out of the connection block.
11. Push terminal block back into the black box. Re-attach the black box to the mounting bracket.

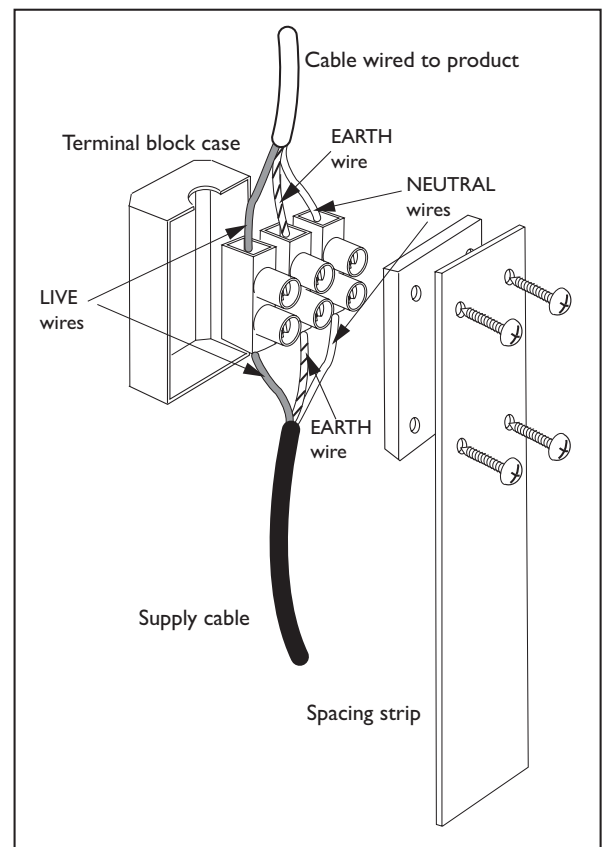

## Check That

- You have correctly identified the wires.
- The connections are tight.
- No loose strands have been left out of the connection block.

## Commissioning

---

8. Fit the lampholder assembly back in position and resecure with the three nuts.
9. Refit the shade and domed nuts.
10. Replace fuse or circuit breaker and switch on. Your light is now ready for use.

## Fitting / Replacing Bulbs

---

When changing a bulb, always switch off at the mains and allow the bulb to cool before handling. Dispose of used bulbs carefully.  
Do not exceed the wattage stated or use a different shape bulb from that indicated on the fitting.  
To access the bulb, remove the domed nuts on top of the shade, and lift off the top. Set aside.  
Relocate the shade top over the screws and secure in place with the domed nuts.

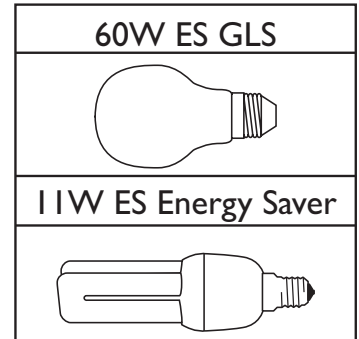

## Care and Cleaning

---

Do not use solvents or abrasive cleaners as these could damage the finish.  
In normal circumstances, stainless steel is very resistant to corrosion. It does however require maintenance to preserve the high quality appearance. Wash the product with warm soapy water, removing all surface deposits. Rinse with clear water and with a soft cloth, wipe dry.  
In some cases, surface corrosion may arise after installation. This is normally caused by tiny iron particles left behind after the brushing process when finishing.  
Wash and dry as detailed above. Then with a soft cloth soaked with a protective oil, wipe all over.  
However if the product is subject to extreme environmental conditions such as marine locations, industrial pollution and acid rain these maintenance procedures should be carried out around four times a year. For severe corrosion, non-abrasive cream cleaners or proprietary stainless steel cleaners should be used to remove the corrosion. Wash and dry as detailed above. Then with a soft cloth soaked with a protective oil, wipe all over.  
Glass parts - Remove and wash in warm water or just use a damp cloth. Do not use abrasive materials as these will damage the finish. Glass parts - Remove and wash in warm water or just use a damp cloth. Do not use abrasive materials as these will damage the finish.  
**Do not clean the units with a pressure washer.**

## Recycling Advice

---



Waste electrical products should not be disposed of with household waste. Please recycle where facilities exist. Check with your Local Authority or retailer for recycling advice.

## Safety Information

---

For your safety, always switch off the supply before changing lightbulbs, cleaning or removing shades.

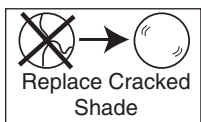

The glass shade must be replaced immediately should the glass shade become cracked or damaged. This fitting must not be used without the glass shade in place.



Saxby Lighting Ltd. BH23 3PE